



E-Box 48100R Specs

Electrical

Nominal Voltage	51.2V
Voltage Range	47.5V–57.6V
Nominal Capacity	100Ah
Nominal Energy	5.12kWh
Recommended Charge/Discharge Current	50A (2.56kW DC)
Maximum Charge/Discharge Current	50A (2.56kW DC)
Peak Discharge Current	102A (5.22kW@15s)

General

Chemistry	LFP
Communication Protocol	CAN/RS485
Dimensions (L x W x H)	17.32 * 24.41 * 4.61 inch
Weight	112.5lbs
Ambient Temperature	14°F ~122°F
Round-Trip Efficiency	≥95%
Cycle Life	≥6000 cycles
Warranty	10 Years
Scalability	16 pcs (81.92kWh) in a group 6 groups (491.52kWh) in a system w/a Hub

Certifications

UL9540 Ed.2(2020), UL9540A, UL1973, CEC, SGIP, OGP_e

Compatibility List of PYTES ESS and Inverters

Main Inverter Partner



Battery Connection Diagram Guide

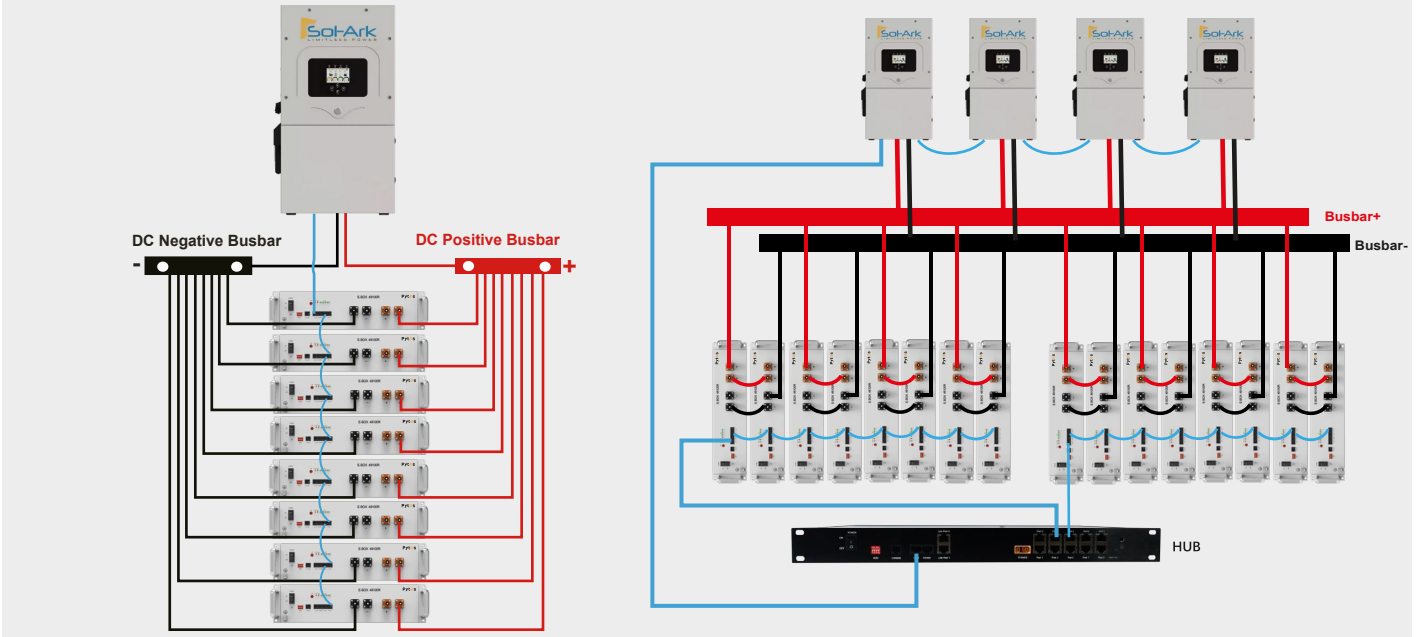

E-Box 48100R Enclosure



48100R Bracket
hold up 1*E-BOX 48100R

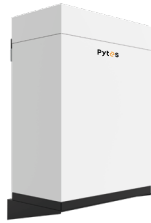

R-BOX
hold up 2*E-BOX 48100R



R-BOX-IP64
hold up 2*E-BOX 48100R



R-BOX-OC(IV)
hold up 4*E-BOX 48100R



Forest RB Plus
hold up 6*E-BOX 48100R

Case Study



E-BOX48100R

- LifePO4
- 100Ah / 5.12kWh
- Dis/Charge 50A
- 6000 Cycles
- 10 Year Warranty

- DSS SGS NA
- IEC 62919
- MSDS 2022
- UL1973 Test Report
- UL1973-Cert
- UL954A
- UN38.3



PYTES (USA) ENERGY, INC

Address: 920 S Holgate St, STE 106, Seattle, Washington, 98134 USA

Site: www.pytesusa.com

Email: pytesusa@pytesgroup.com



More Catalogs



LinkedIn



Facebook



YouTube



www.pytesusa.com



Pytes