

Ballast Block Carrier

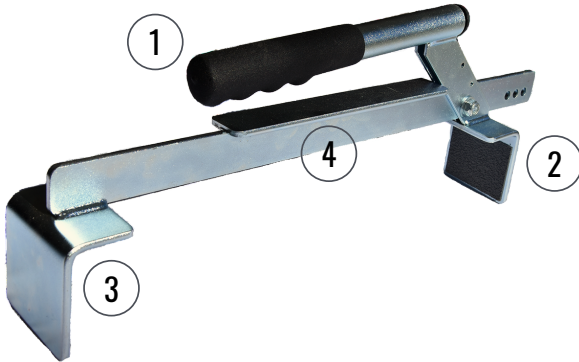

Features

Comfortable Handle

- 1 Tubular rubber grip handle with finger protection provides comfort for continued use.

Superior Grip

- 2 Specially designed grip pads provide added control when carrying bricks to keep bricks from slipping out when being transported.

Heavy Duty Construction

3 Heavy gauge steel construction with a 100 lbs lift capacity.

Finger Flange

4 The finger flange is designed to remove the tool from the block with one hand quickly and efficiently.

TESTIMONIALS

- Reduces strain on the fingers and forearms
- Increases speed balance and mobility
- Eliminates bending at the waist and reduces back strain
- Quick & easy pick-up and drop off bricks

Solar Tools USA

208. 254.1745
sales@solartoolsusa.com
www.solartoolsusa.com



Ballast Block Carrier

FASTER, SAFER, EASIER

Created out of the frustrating daily grind of manually carrying CMU blocks.

The Ballast Block Carrier is designed to assist with the lifting and carrying of CMU blocks and is especially helpful when carrying two blocks at a time.

Gravity-Fed Grip



Custom designed specific to the railing manufacturer you select.

Tubular Handel



Comfortable rubber grip with finger protection. This allows for continued use with little strain on your hands

Evenly Dispersed Weight



Allows you to easily carry CMU blocks with a natural stance reducing muscle strain.

We know first hand the struggles you as a solar installer face. We see you, we hear you and we are one of you!

Don't Be This Guy



Be This Guy

