



RSD-S-PLC

- Meets NEC 2017 & 2020 (690.12) requirements
- Executes rapid shutdown of system when Transmitter-PLC signal is absent
- Meets SunSpec requirements

The RSD-S-PLC meets SunSpec requirements, maintaining normal function by continually receiving a heartbeat signal from the APsmart Transmitter. The RSD executes rapid system shutdown when the Transmitter signal is absent. Users can manually execute rapid shutdown using Transmitter breaker switch.

> RSD-S-PLC TECHNICAL DATA

MODEL

RSD-S-PLC

INPUT DATA (DC)

Input Operating Voltage Range	8-80V
Maximum Cont. Input Current (Imax)	15A
Maximum Short Circuit Current (Isc)	25A

OUTPUT DATA (DC)

Output Operating Voltage Range	8-80V
Maximum System Voltage	1000V/1500V
Maximum Series Fuse Rating	30A

MECHANICAL DATA

Operating Ambient Temperature Range	-40°F to +185°F (-40 °C to + 85 °C)
Dimensions (without cable & connectors)	5" x 1.2" x 0.6"(129 mm x 30 mm x 16 mm)
Cable Length	Input 250mm/Output 1200mm
Cable Cross Section Size	UL:12AWG
Connector	Input: Stäubli MC4 PV-KBT4&KST4 or Customized Output: APsystems specified or Customized
Enclosure Rating	NEMA Type 6P/IP68
Protection Temperature	100°C

FEATURES & COMPLIANCE

Communication	PLC
Safety Compliance	NEC 2017 & 2020 (690.12); UL1741; CSA C22.2 No. 330-17; IEC/EN62109-1; 2PFG2305
	FCC Part15; ICES-003; IEC/EN61000-6-1/-2/-3/-4



> RSD-S-PLC WIRING DIAGRAM

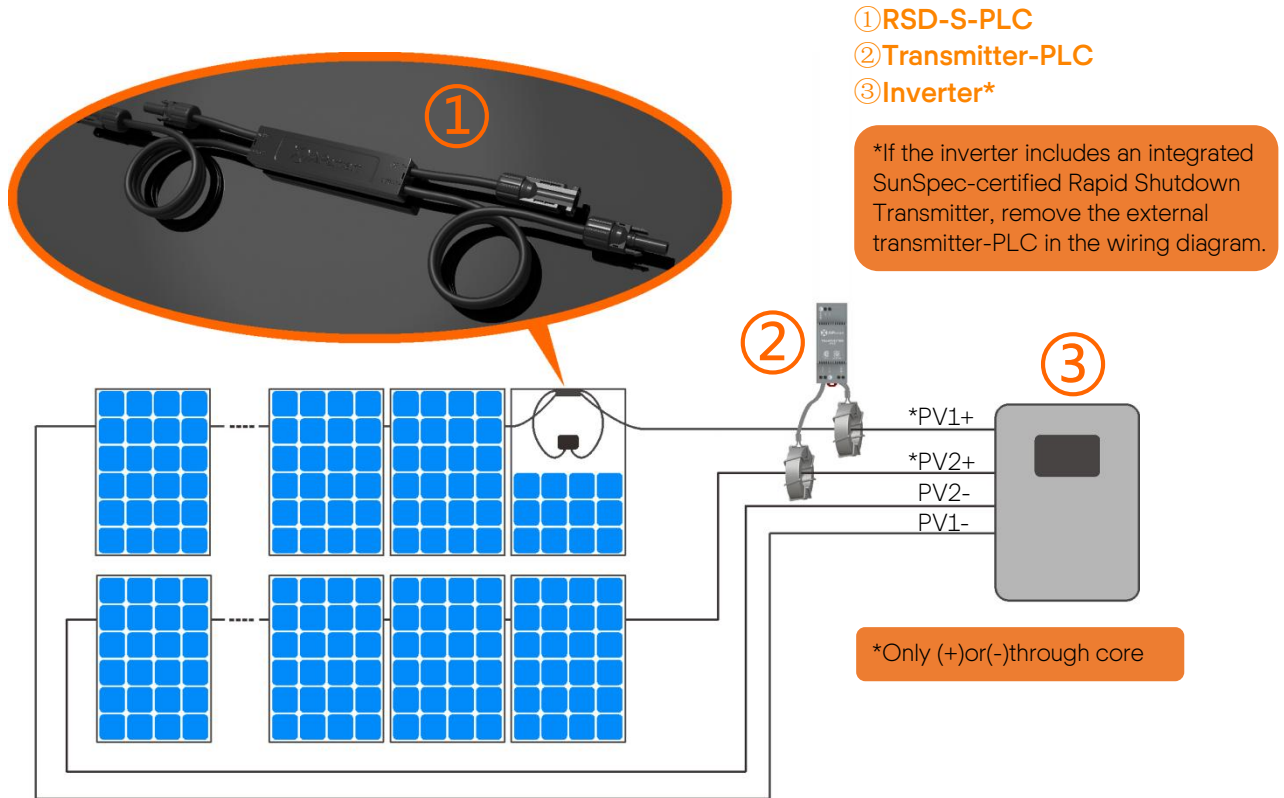

> WORKING SCHEMATIC DIAGRAM

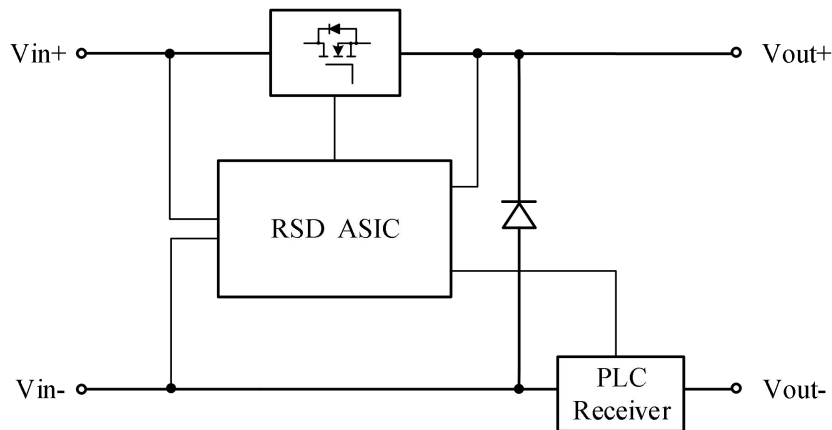

ORDERING INFORMATION	
415002	1500V UL, 1.2m cable, Stäubli MC4 PV-KBT4&KST4
415001	1000V UL, 1.2m cable, Customized connector