



## APPLICATION:

The GroundTrac system is designed with a minimum amount of installed footings at greatly reduced labor. The system integrates with ordinary 1-1/2" schedule #40 galvanized water pipe. This ground mount solution includes virtually everything needed to install modules with vertical posts up to 5' from rear footing, 30" from front footing. The installer will only need pipe, concrete and basic construction skills to complete the installation. This fully engineered system utilizes Professional Solar Products' patented Slide-n-Clamp™ module clamps and support rail.



## WARNING

All Professional Solar Products (ProSolar) are engineered and tested to withstand stated specifications (as stated on published specification sheets) when installed properly. Failure to install properly may decrease the performance of the installation.



## SAFETY

All regional safety requirements should be followed when installing Professional Solar Products. All equipment/tools should be properly maintained and inspected prior to use. This installation manual is intended for use by professional installers with a working knowledge of construction principles.

## Symbol Legend

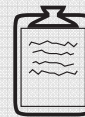

Explanation or Install Tip



Important product performance information



Critical for Safety

## Tool List

- Post hole digger or powered auger
- ProSolar grade stake kit
- Cordless drill
- 1/2" wood drill bit
- 1/2" & 9/16" deep socket & ratchet (or impact gun)
- Sledge hammer (small-approx. 14")
- 3-1/2" (min) C-clamps
- String Line and line level OR builders/laser level
- Pipe wrenches (two required)
- Tape Measure

- 3/16" long-arm hex wrench
- Torque wrench with 3/16" hex bit socket
- Cordless reciprocating saw/ band saw
- Wheelbarrow or concrete pump

## FOR UNSLOTTED RAIL—ADD:

- 1/2" Irwin® #10 UniBit™
- Framing square
- Sharpie™ marker

## Installation steps overview

- |  |   |  |
|--|---|--|
| 1) Dig footings                          | 5) Insert pipe and center               | 8) Pour concrete                                     |
| 2) Assemble re-usable grade stake forms  | 6) Fasten Drop-N-Lock / U-bolt Assembly | 9) Remove re-usable stakes and install solar modules |
| 3) Insert grade stakes / lay pipe & tees | 7) Attach rail spacers every 10'        | 10) Completed installation                           |
| 4) Measure & cut vertical pipes          |   |  |

## Step 1: Dig footings

Dig footings.

Lateral footing spans listed on page 6.

Front to rear footing spans listed in angle charts on page 6.

(Footing depths may vary depending on site specific conditions such as sloped hillsides. Review site specific requirements with local building department as necessary.)

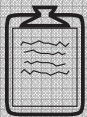

To speed up installation it is recommended to use a 12" power auger to dig your footings.

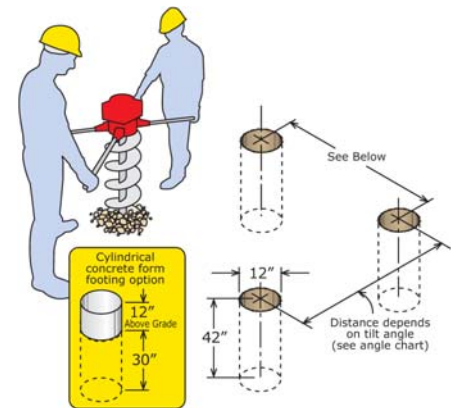

## Step 2: Build grade stake forms

Assemble re-usable ProSolar grade stakes).

Recommend 2"x4" vertical support. Drill 2" x 4" with 1/2" drill bit using grade stake as hole template.

Assemble bolt, washer, spacer block and grade stake and tighten using 9/16" socket. Attach 1"x 4" wooden horizontal support using 3-1/2" (min.) C-clamps.

Grade stake kit includes: 24" threaded metal stakes, aluminum spacer blocks, bolts and washers.

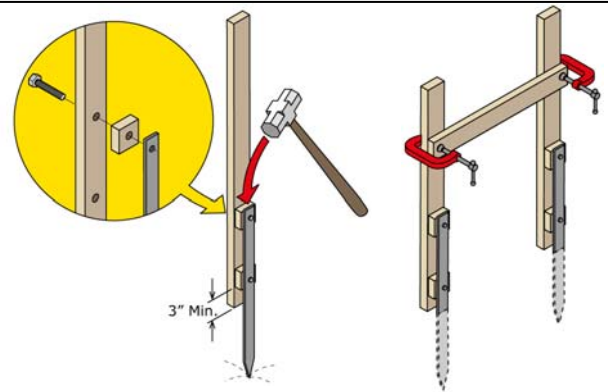

## Step 3: Insert grade stakes and lay horizontal pipe support

Drive grade stakes with sledgehammer beside each footing and level 1" x 4" supports using string line/line level or laser level.

Place horizontal 1-1/2" schedule 40 galvanized pipe with slip-on Hollaender® Tees along 1" x 4" supports. Adjust C-clamps as necessary to level pipe. Use pipe wrenches to couple pipe lengths as necessary.

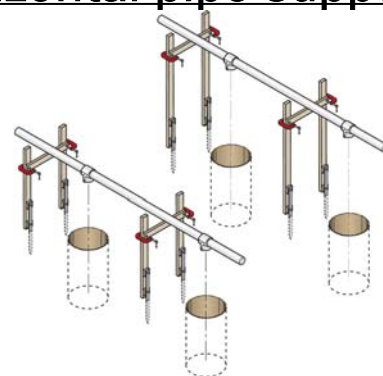

## Step 4: Measure pipe heights and cut

Measure vertical pipe lengths with measuring tape from bottom of footing to horizontal pipe. Deduct 2" from length to avoid pipe contact with bottom of footing moisture. Note measured lengths.

Cut pipe lengths using a chop saw, reciprocating saw, or portable band saw



Use only 1-1/2" Schedule #40 Galvanized water pipe (not fence tube) for your supports.

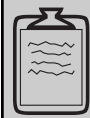

Standard 21' length water pipe with pre-attached couplers readily available at plumbing supply houses.

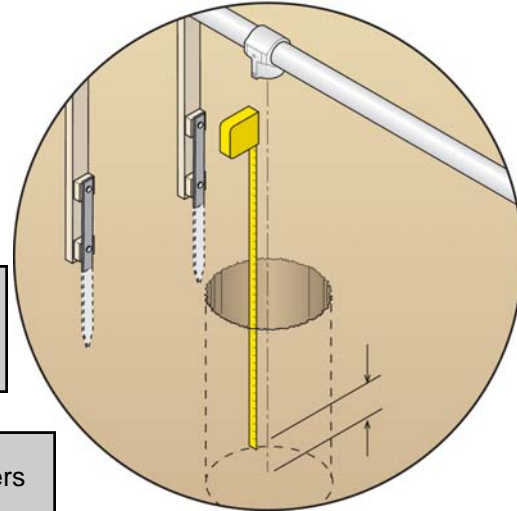

## Step 5: Insert vertical support pipes and center

Insert vertical pipes into tees and fasten lower tee set screw with long-arm hex key.

Center vertical pipes in footings by sliding left or right.



1-1/2" Schedule 40 pipe max end overhang of 2 feet.

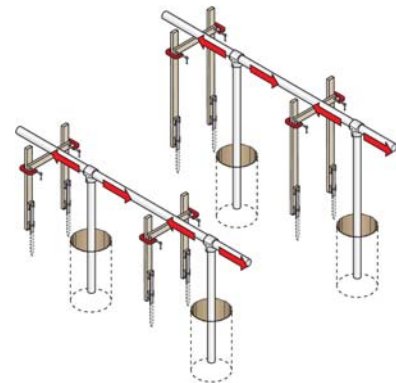

## Step 6: Attach initial support rails with Drop-N-Lock U-bolt assembly

Rest pre-slotted rail on top of horizontal pipes and insert U-bolt. Place Drop-N-Lock support rail insert into the rail and align with U-bolt. Hand tighten nuts.



U-bolt nuts should be evenly tightened to avoid u-bolt misalignment.

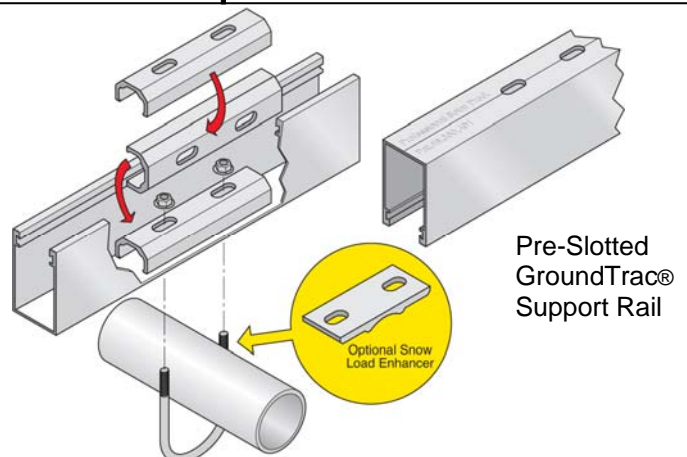

## Step 7: Attach support rails (spacers) every 10'

Install at least one rail approximately every 10' for proper pipe spacing.

If not using slotted rail, see page 7 for drilling rail locking holes.

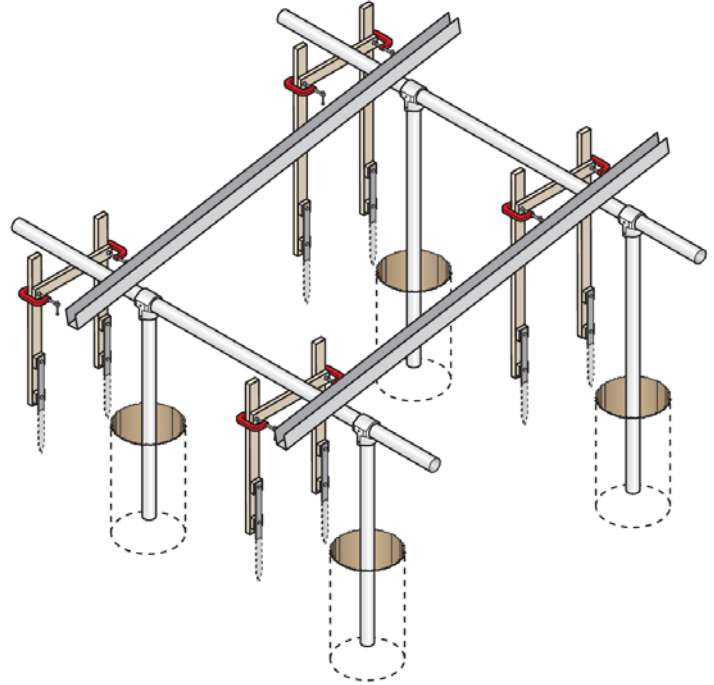

## Step 8: Pour concrete

Pour or pump mixed concrete into footings.  
Let cure.

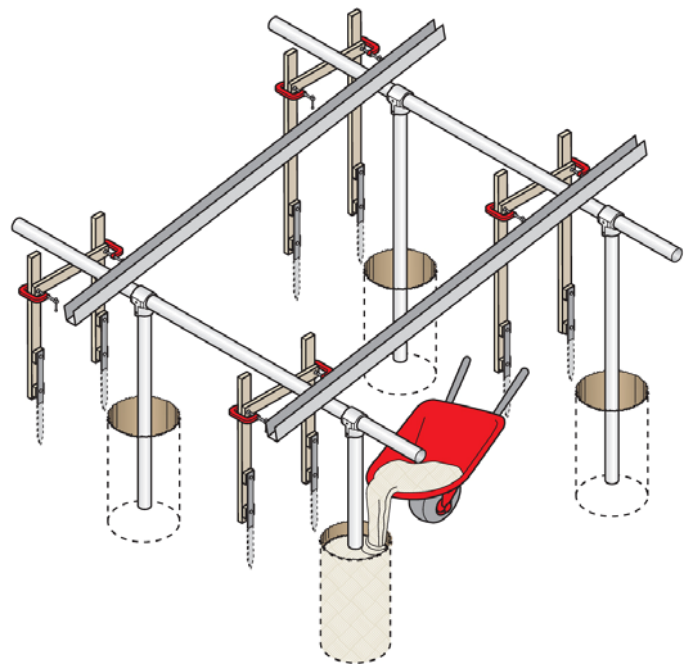

Extruded edges of the aluminum can be sharp. Treat any sharp edges as necessary to prevent injury.

## Step 9: Remove re-usable forms and install modules

Remove grade stakes. Tighten all tee set screws, both upper and lower, to 17 ft-lbs with torque wrench and hex bit socket.

Adjust initial rails to final location. Install remaining rails.

Tighten all U-bolt nuts evenly with 1/2" socket or impact gun .

Install solar modules with pre-assembled ProSolar clamping hardware.

Install ProSolar EZ rail end caps with adhesive.

Install 1-1/2" plastic pipe end caps for schedule 40 pipe as necessary.

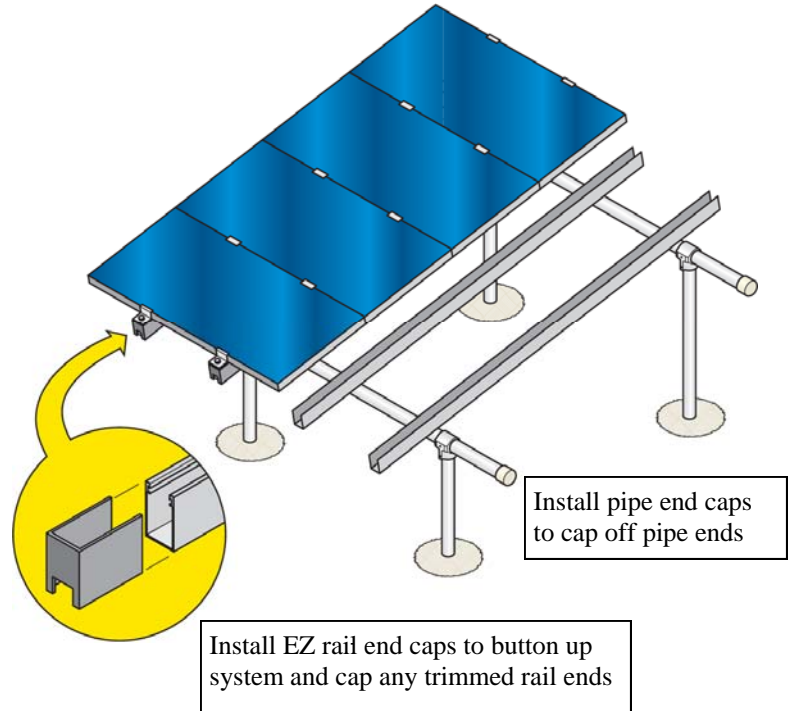

## Step 10: Completed GroundTrac® Installation

Completed GroundTrac® Installation.

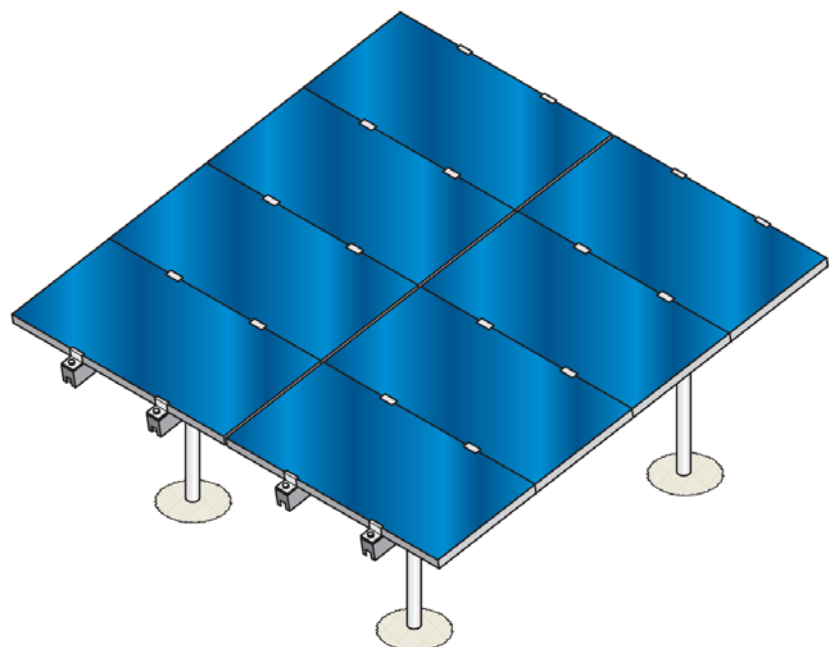
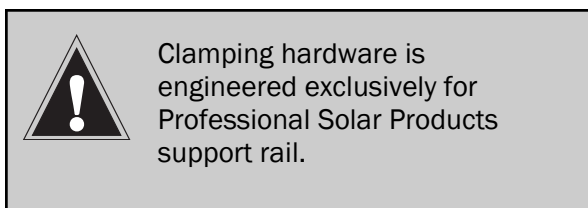

**124" x 2-1/2" Support Rail**  
Supports up to (3) 39.5" Wide Modules

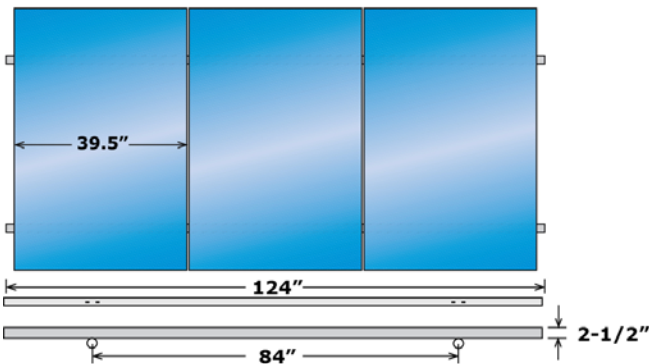

**136" x 2-1/2" Support Rail**  
Supports up to (4) 32.5" Wide Modules

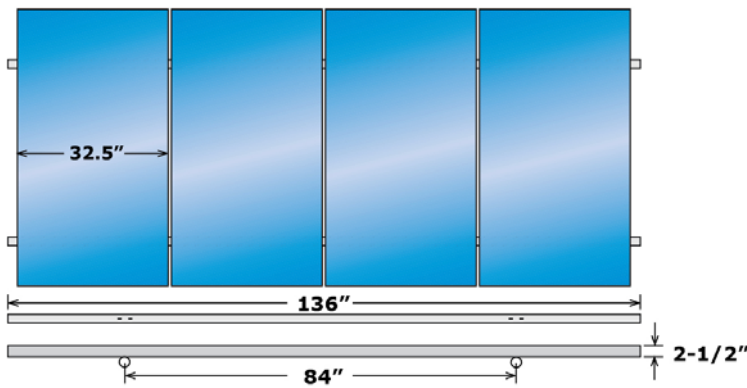

**164" x 3" Support Rail**  
Supports up to (4) 39.5" Wide Modules

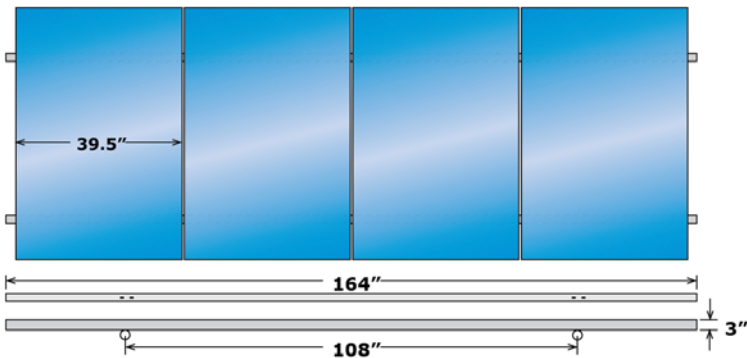

Array Angle	Footing Distance
0°	84"
5°	84"
10°	83"
15°	81"
20°	79"
25°	76"
30°	73"

**124" and 136" Rail  
Angle Chart**

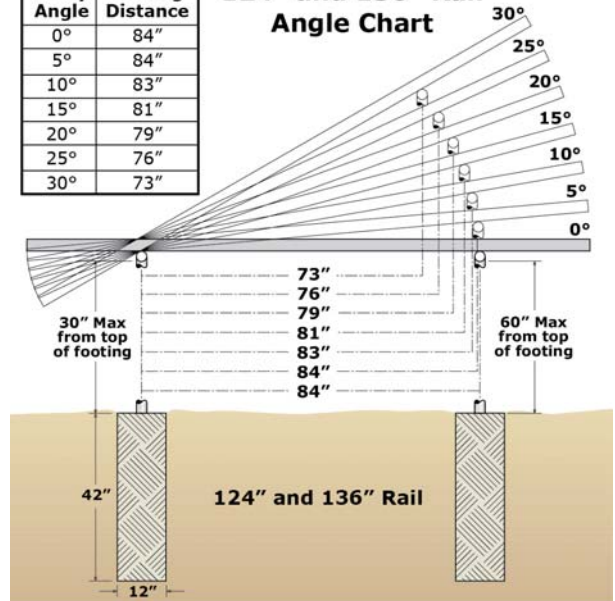

**164" Rail  
Angle Chart**

Array Angle	Footing Distance
0°	108"
5°	108"
10°	106"
15°	104"
20°	101"

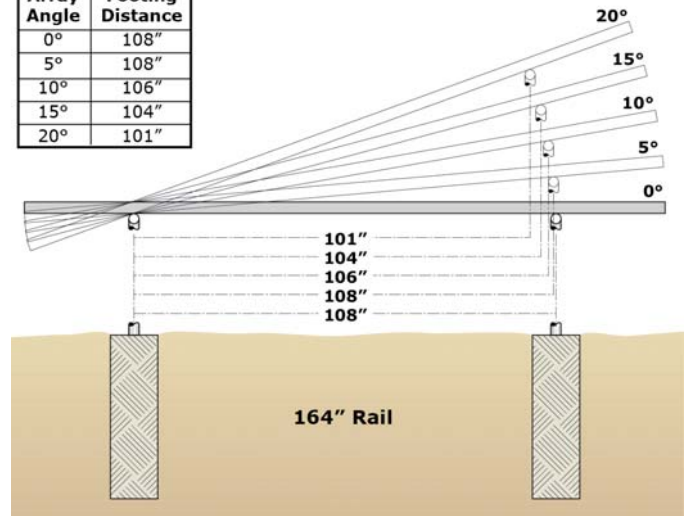

GroundTrac® Rail Sizes	124" x 2-1/2"	136" x 2-1/2"	164" x 3"
Number of Modules	(3) 39.5" wide modules	(4) 32.5" wide modules	(4) 39.5" wide modules
Lateral footing span (max) non-snow load	10'	10'	8'
Lateral footing span (max) 30 lb/ft² snowload	6'	6'	Not snowload rated
Front to back footing spacing	See Angle Chart	See Angle Chart	See Angle Chart
Pre-slotted rails at:	84" on Center	84" on Center	108" on Center

## Step 11: Drilling holes for un-slotted rails

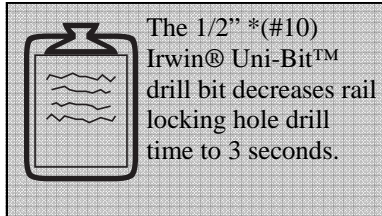

The 1/2" (#10) Irwin® Uni-Bit™ drill bit decreases rail locking hole drill time to 3 seconds.

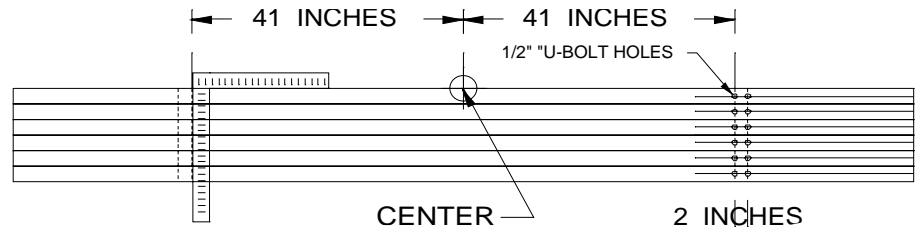

If not using pre-slotted rails, use the 1/2" diameter Irwin™ Uni-Bit® (#10) short nose drill bit to drill U-bolt assembly rail locking holes.

### 124" & 136" Support Rail Lengths (see page 6 for span illustration)

Upper pipe to lower pipe span (distance between U-bolts): 84" on center  
U-bolt locking holes 41" from center (see above illustration)

### 164" Support Rail Length (see page 6 for span illustration)

Upper pipe to lower pipe span (distance between U-bolts): 108" on center  
U-bolt locking holes 53" from center (not shown)

Align several rails side by side, as shown.

Using a square and Sharpie™ marker, mark hole locations along integrated rail bottom drill guide.

Drill marked locations with cordless drill and Uni-Bit® speed drill bit