

NOTES:

1. ENSURE CLAMP CAN BE INSTALLED INTO SNAPRACK ULTRA RAIL AND EASILY SLIDES
2. ENSURE CLAMP CAN BE TIGHTENED ONTO BOTH 46MM AND 30MM MODULES WHEN INSTALLED IN ULTRA RAIL
3. PART WEIGHT: .155 LB
4. UNITS:
IN, LB, DEG
[MM, KG, DEG]

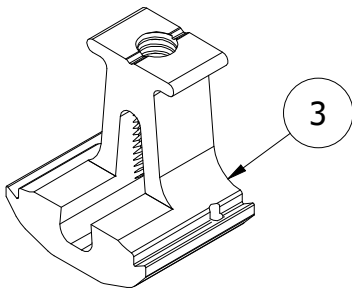

EXPLODED

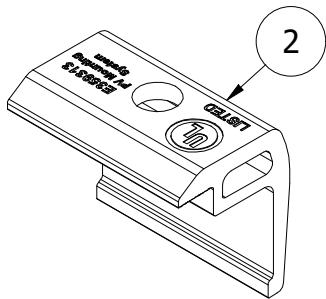
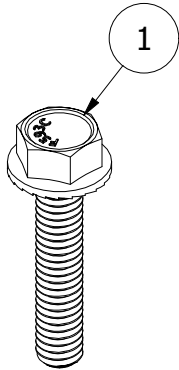
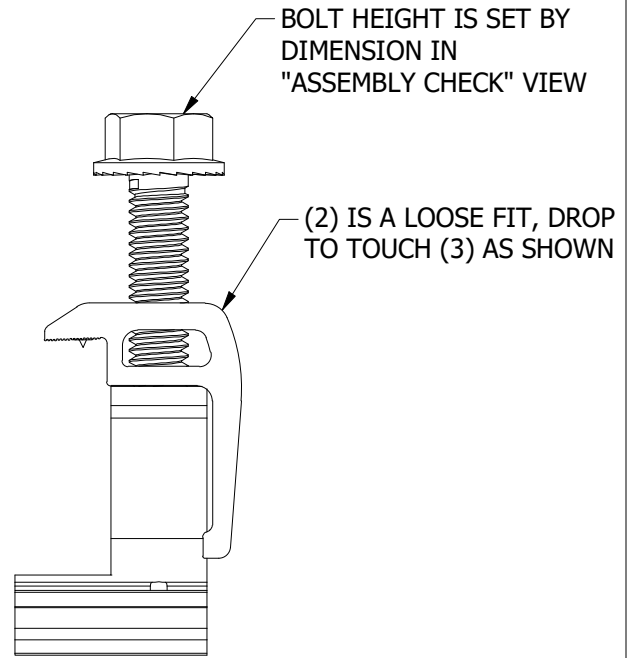

AS SHIPPED

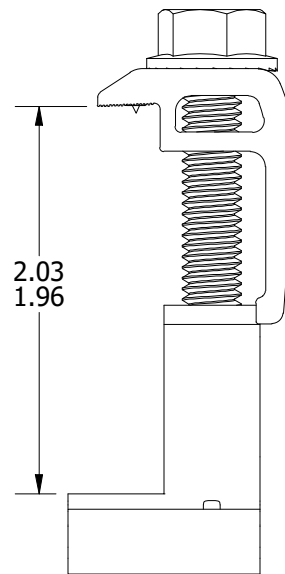

ASSEMBLY CHECK

ASSEMBLER:

INSPECTOR:

PARTS LIST

ITEM	QTY	PART NUMBER	DESCRIPTION
1	1	162-01101	BOLT, FLANGE SERRATED, 5-16IN-18 X 1-1-2IN, SS
2	1	232-02065S	SNAPRACK, ULTRA END CLAMP, TOP, SILVER
3	1	232-02066S	SNAPRACK, ULTRA END CLAMP, BASE, SILVER

DESCRIPTION:

**SNAPRACK, ULTRA RAIL END CLAMP,
SILVER**

DRAWN BY: M.AFFENTRANGER

APPROVED BY: W.ARBUCKLE

REVISION:

A 11/5/2019 NU001078 MJA

B 12/18/2019 NU001086 MJA

B 8/11/2021 NU002132 MJA

SnapNrack™
Solar Mounting Solutions

Sunrun South LLC

595 MARKET STREET, 29TH FLOOR • SAN FRANCISCO, CA 94105 USA
PHONE (415) 580-6900 • FAX (415) 580-6902

PART NUMBER:

242-02072

SCALE:

DNS

REV:

B

THE INFORMATION IN THIS DRAWING IS CONFIDENTIAL AND PROPRIETARY. ANY REPRODUCTION, DISCLOSURE, OR USE THEREOF IS PROHIBITED WITHOUT THE WRITTEN CONSENT OF SUNRUN SOUTH LLC.