

PARTS LIST

ITEM	QTY	PART NUMBER	DESCRIPTION
1	1	162-03252-S	BOLT, FLANGE, SERRATED, 5-16IN-18 X 2IN, SS
2	1	232-02521	SNAPNRACK, RL UNIVERSAL, MOUNT SPRING, SS
3	1	232-04064-S	SNAPNRACK, SPEEDSEAL FOOT, BASE, SEALING, SILVER
4	1	232-02462	SNAPNRACK, ULTRA RAIL MOUNT THRU PRC, CLEAR
5	1	232-02465	SNAPNRACK, ULTRA RAIL MOUNT TAPPED PRC, CLEAR
6	1	165-01300	5-16IN X 3-4IN SS FLAT WASHER

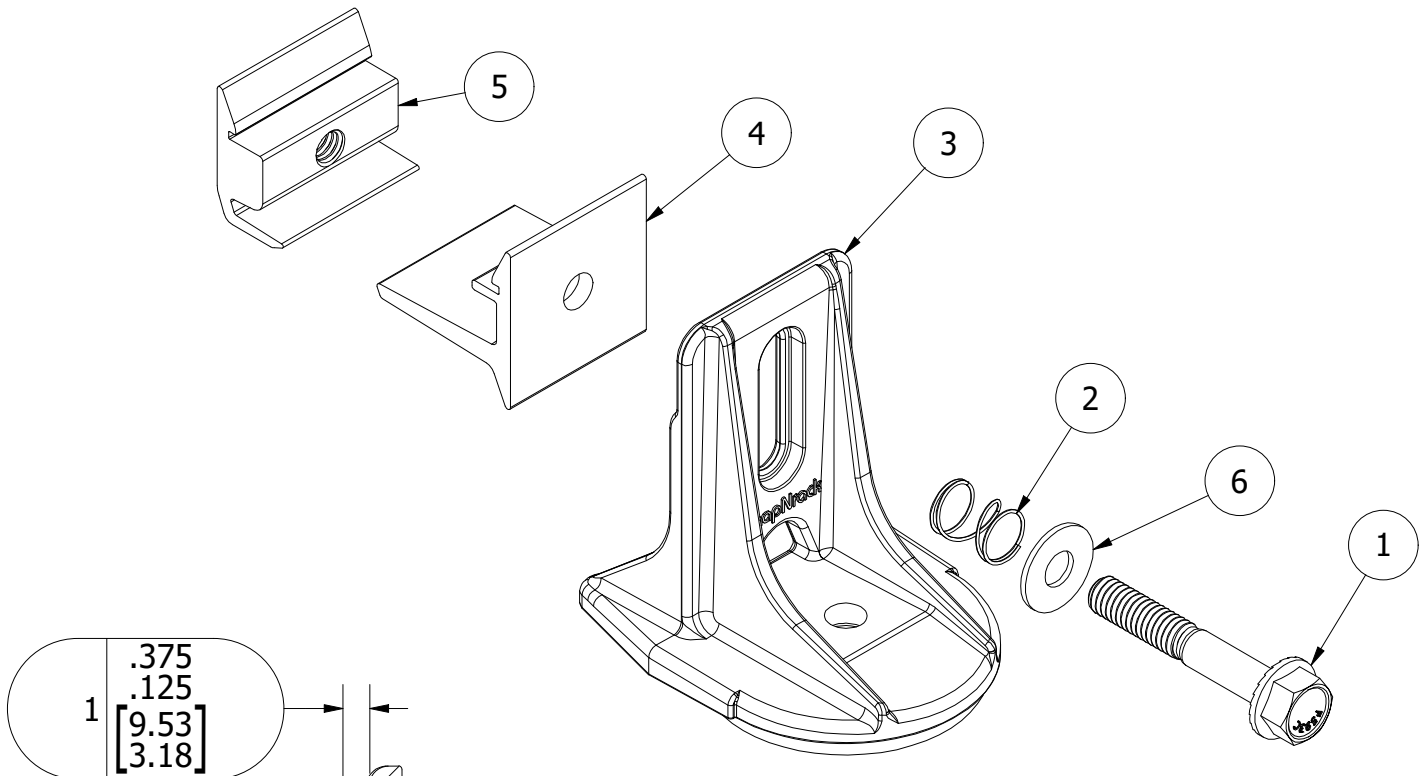

EXPLODED

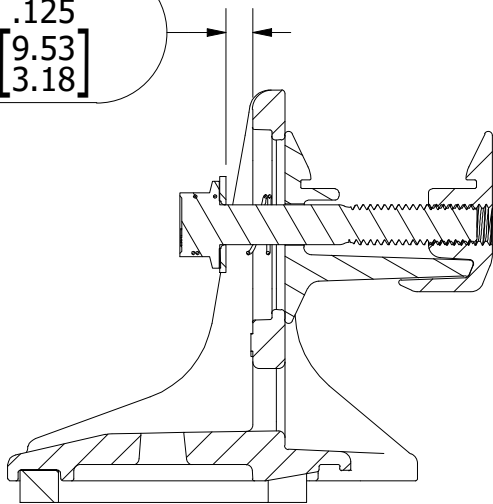

SECTION

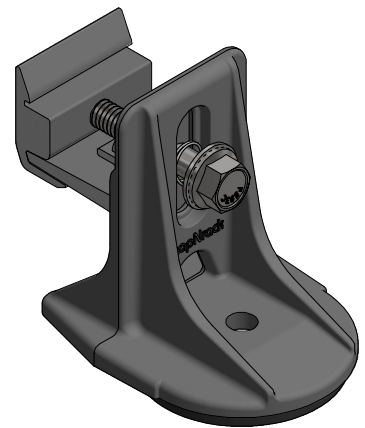

ISO

PART WEIGHT: 0.457 lbmass  
 UNITS: IN, LB, DEG [MM, KG, DEG]

DESCRIPTION:  
 SNAPNRACK, UR SPEEDSEAL FOOT, SILVER

DRAWN BY: M.AFFENTRANGER

APPROVED BY: W.ARBUCKLE

REVISION:

A	3/12/2020	NU001084	MJA
B	7/22/2020	NU001109	MJA
C	4/26/2022	NU003221	DR

SnapNrack™  
 Solar Mounting Solutions

SUNRUN INSTALLATION SERVICES, INC.

PART NUMBER:  
 242-02163

SCALE:  
 DNS

REV:  
 C

225 BUSH STREET, SUITE 1400 • SAN FRANCISCO, CA 94104 USA  
 PHONE (877) 732-2860 • CONTACT@SNAPNRACK.COM

THE INFORMATION IN THIS DRAWING IS CONFIDENTIAL AND PROPRIETARY. ANY REPRODUCTION, DISCLOSURE, OR USE THEREOF IS PROHIBITED WITHOUT THE WRITTEN CONSENT OF SUNRUN SOUTH LLC.