

DESCRIPTION:
SNAPNRACK, TDS, ULTRA RAIL HANGER BOLT CLAMP

DOC NUMBER:
 SNR-DC-01368

SnapNrack®

PART NUMBER(S):

242-01128

DRAWN BY:
 H.WULFEKOETTER

REV: **B** DATE: 1/23/2023

SUNRUN INSTALLATION SERVICES INC.

225 BUSH STREET, SUITE 1400 • SAN FRANCISCO, CA 94104 USA
 PHONE (877) 732-2860 • CONTACT@SNAPNRACK.COM

THE INFORMATION IN THIS DRAWING IS CONFIDENTIAL AND PROPRIETARY. ANY REPRODUCTION, DISCLOSURE, OR USE THEREOF IS PROHIBITED WITHOUT THE WRITTEN CONSENT OF SUNRUN SOUTH LLC.

UNITS: IN, LB, DEG [MM, KG, DEG]

SHEET: 1:2

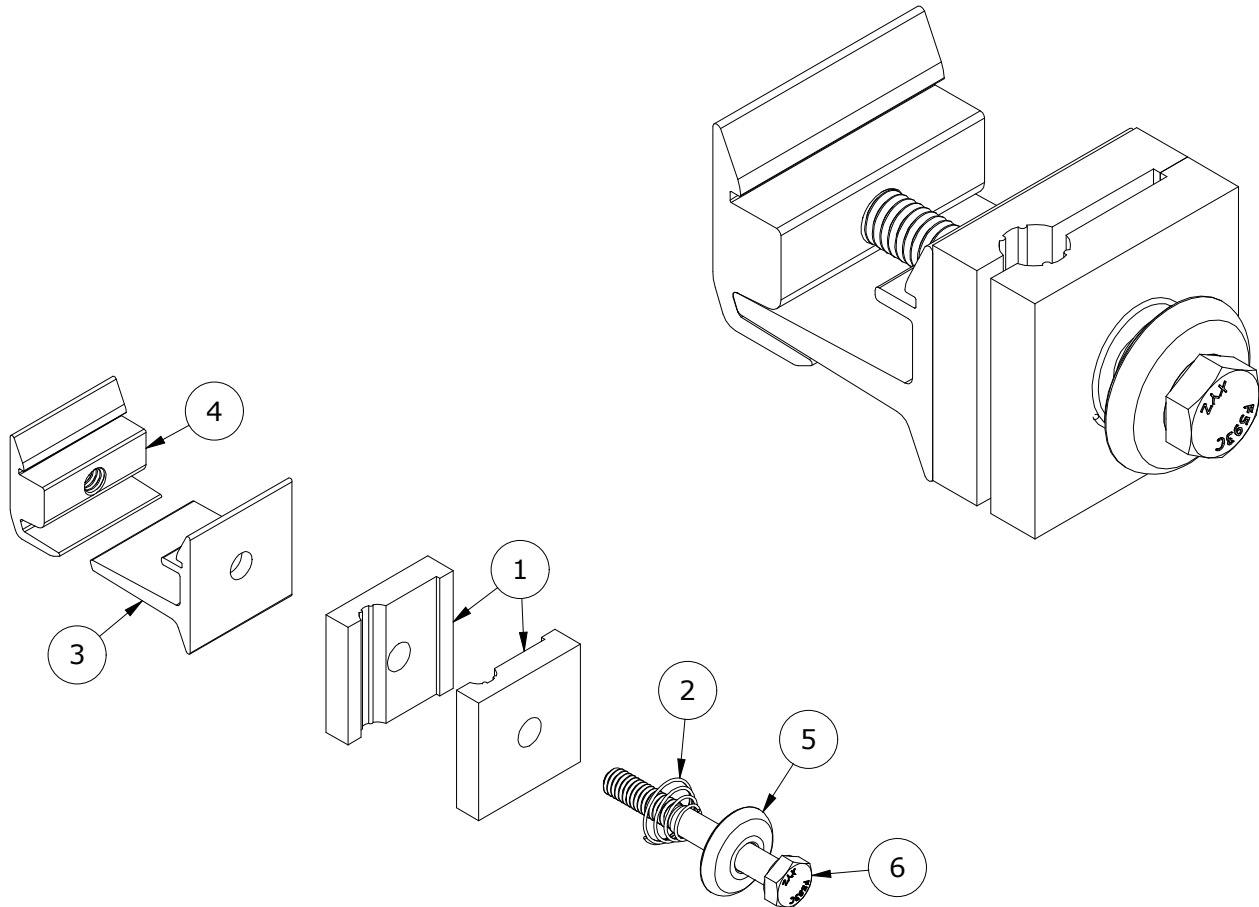

PARTS LIST

ITEM	QTY	DESCRIPTION
1	2	SNAPNRACK, HANGER BOLT CLAMP
2	1	SNAPNRACK, ULTRA RAIL MOUNT SPRING
3	1	SNAPNRACK, ULTRA RAIL MOUNT THRU PRC, CLEAR
4	1	SNAPNRACK, ULTRA RAIL MOUNT TAPPED PRC, CLEAR
5	1	SNAPNRACK, ULTRA RAIL MOUNT SPRING CAGE
6	1	BOLT, HEX CAP, 5/16IN-18 X 2-1/2IN, SS

MATERIALS: 6000 SERIES ALUMINUM, STAINLESS STEEL

DESIGN LOAD (LBS): 318 UP, 394 DOWN, 417 SIDE

ULTIMATE LOAD (LBS): 1192 UP, 1152 DOWN, 1500 SIDE

TORQUE SPECIFICATION: 12 FT-LBS

CERTIFICATION: UL 2703, FILE E359313

WEIGHT (LBS): 0.33

DESCRIPTION:
SNAPNRACK, TDS, ULTRA RAIL HANGER BOLT
CLAMP

DOC NUMBER:
SNR-DC-01368

SnapNrack®

PART NUMBER(S):

242-01128

DRAWN BY:
H.WULFEKOETTER

REV: **B** DATE:
1/23/2023

SUNRUN INSTALLATION SERVICES INC.

225 BUSH STREET, SUITE 1400 • SAN FRANCISCO, CA 94104 USA
PHONE (877) 732-2860 • CONTACT@SNAPNRACK.COM

THE INFORMATION IN THIS DRAWING IS CONFIDENTIAL AND PROPRIETARY. ANY
REPRODUCTION, DISCLOSURE, OR USE THEREOF IS PROHIBITED WITHOUT THE
WRITTEN CONSENT OF SUNRUN SOUTH LLC.

UNITS: IN, LB, DEG [MM, KG, DEG]

SHEET: 2:2

