

PARTS LIST

ITEM	QTY	PART NUMBER	DESCRIPTION
1	1	162-03252-S	BOLT, FLANGE, SERRATED, 5-16IN-18 X 2IN, SS
2	1	232-02521	SNAPRACK, RL UNIVERSAL, MOUNT SPRING, SS
3	1	232-02533S	SNAPRACK, UMBRELLA L FOOT, STEPPED, CLEAR
4	1	232-02462	SNAPRACK, ULTRA RAIL MOUNT THRU PRC, CLEAR
5	1	232-02465	SNAPRACK, ULTRA RAIL MOUNT TAPPED PRC, CLEAR
6	1	165-01300	5-16IN X 3-4IN SS FLAT WASHER

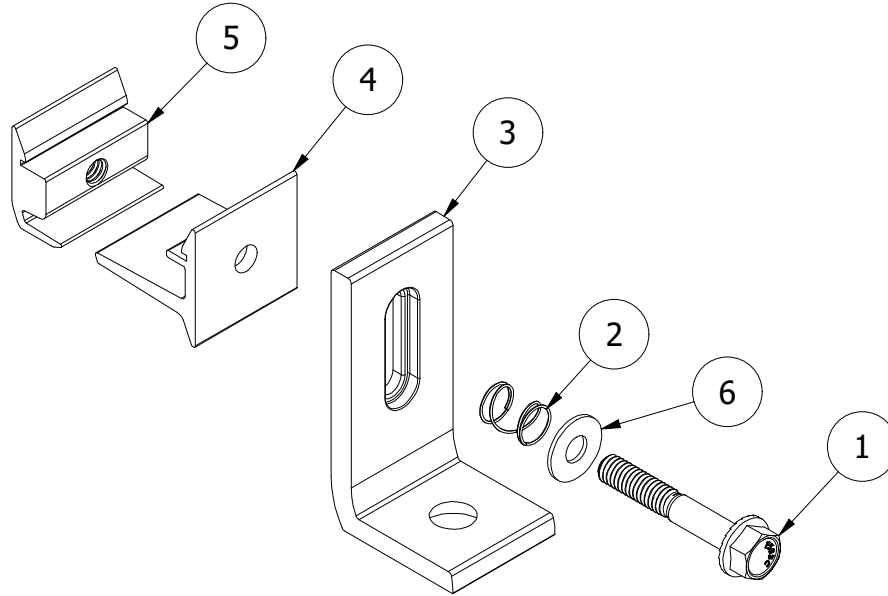

1 .500 - .150
[12.70 - 3.81]

EXPLODED

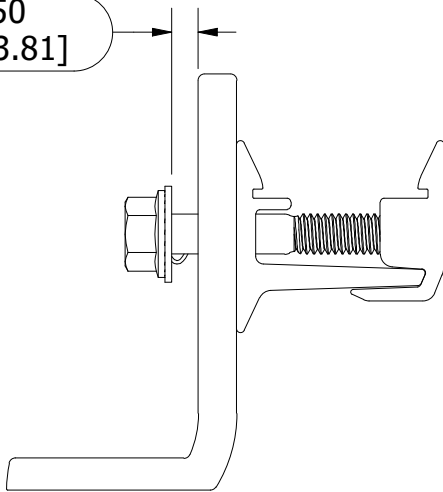

SIDE

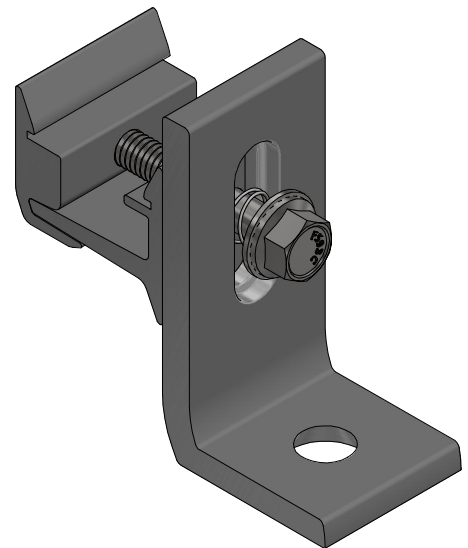

ISO

PART WEIGHT: 0.361 lbmass
UNITS: IN, LB, DEG [MM, KG, DEG]

DESCRIPTION:
SNAPRACK, ULTRA RAIL UMBRELLA L FOOT, SILVER

DRAWN BY: M.AFFENTRANGER

APPROVED BY: W.ARBUCKLE

REVISION:

A	8/14/2017	NEW ITEM	MJA
B	9/6/2017	NU000671	MJA
C	7/24/2020	NU001117	MJA
D	4/26/2022	NU003221	DR

SnapNrack™
Solar Mounting Solutions

SUNRUN INSTALLATION SERVICES, INC.

225 BUSH STREET, SUITE 1400 • SAN FRANCISCO, CA 94104 USA
PHONE (877) 732-2860 • CONTACT@SNAPNRACK.COM

THE INFORMATION IN THIS DRAWING IS CONFIDENTIAL AND PROPRIETARY. ANY REPRODUCTION, DISCLOSURE, OR USE THEREOF IS PROHIBITED WITHOUT THE WRITTEN CONSENT OF SUNRUN SOUTH LLC.

PART NUMBER:
242-01219

SCALE:
DNS

REV:
D